

# RSE Camshaft Spec Card

PART NAME **SPEC-R** ENGINE **G4KF**

PART NUMBER SET **RA301A-HY01B** IN **RA301C-HY01B** EX **RA301E-HY01B**

GRIND	IN	272° /11.50mm	-
	EX	272° /11.00mm	-

LIFT	IN	@CAM 11.50mm	@VALVE 11.30mm
	EX	@CAM 11.00mm	@VALVE 10.70mm

LOBE CENTER(°)	IN	128.0
	EX	122.0

BASE CIRCLE	IN	Φ34.4
	EX	Φ36.4

VALVE CLEARANCE WHEN COLD	IN	0.20
	EX	0.30

ROCKER ARM RATIO*	-
-------------------	---

\* ALL LIFTS ARE BASED ON ZERO LASH AND THORETICAL ROCKER ARM RATIOS

CAM TIMING		OPENS(°)	CLOSES(°)		Actual Duration @ Opening(°)
Actual Duration Valve Lift	IN	BTDC 8.0	ABDC 84.0		272.0
	EX	BBDC 78.0	ATDC 14.0		272.0

Values shown are, from start to the end of actual duration. (Excluding the ramp values)

CAM TIMING		OPENS(°)	CLOSES(°)		TOTAL DURATION(°)
at 1mm Valve Lift	IN	BTDC -7.0	ABDC 68.0		241.0
	EX	BBDC 62.0	ATDC -3.0		239.0

Values are of actual duration from start to end of 1mm value points. (Excluding the ramp values)

CAM TIMING		OPENS(°)	CLOSES(°)		TOTAL DURATION(°)
at 0.05" Valve Lift	IN	BTDC -10.0	ABDC 66.0		236.0
	EX	BBDC 59.0	ATDC -6.0		233.0

Values are of actual duration from start to end of 0.05" value points. (Excluding the ramp values)

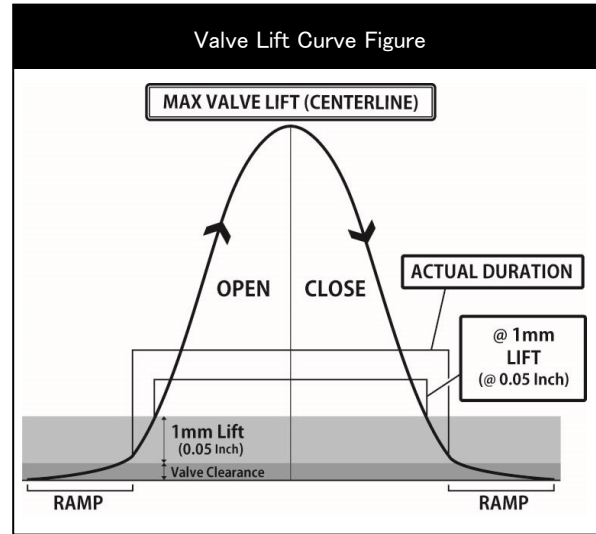

REQUIRED VALVE SPRING SPEC	
NORMAL HEIGHT	41.6mm
SET LENGTH	35.0mm
LIFT LENGTH	23.0mm
COMPRESSED HEIGHT	21.5mm
SET LOAD	27.0kgf ± 7%
LIFT LOAD	85.0kgf ± 7%
PART NUMBER	

REQUIRED PARTS	
PRODUCT NAME	PART NUMBER

Dowel pin position when first cam lobe is pointing upwards.

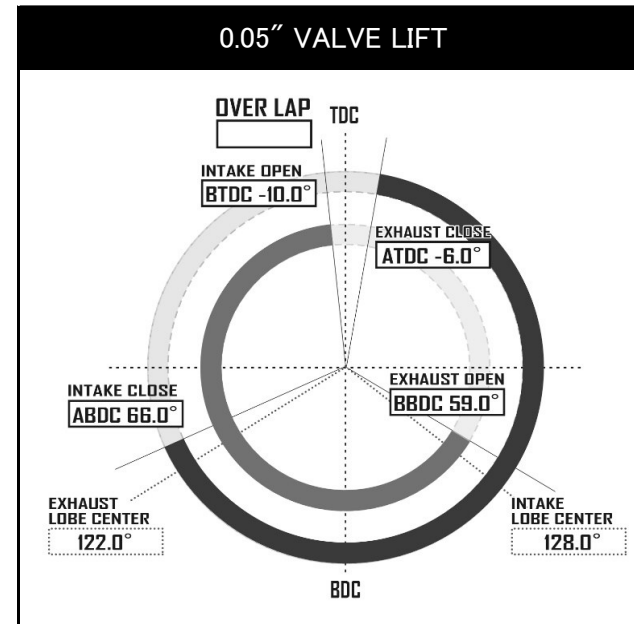
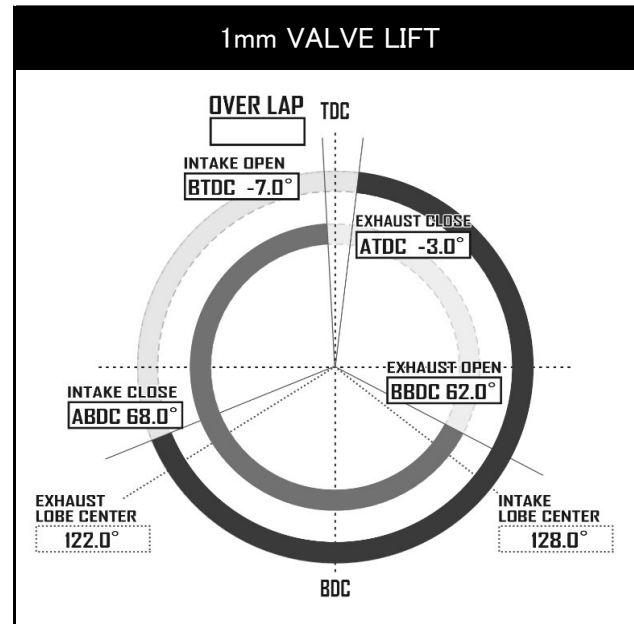
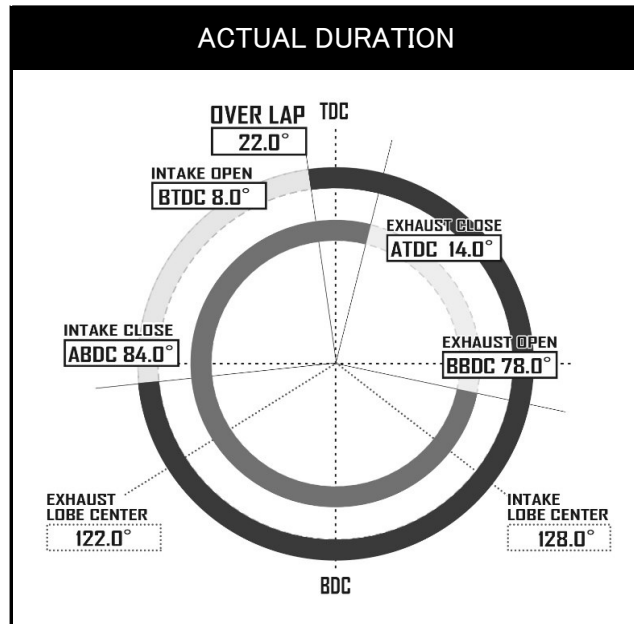
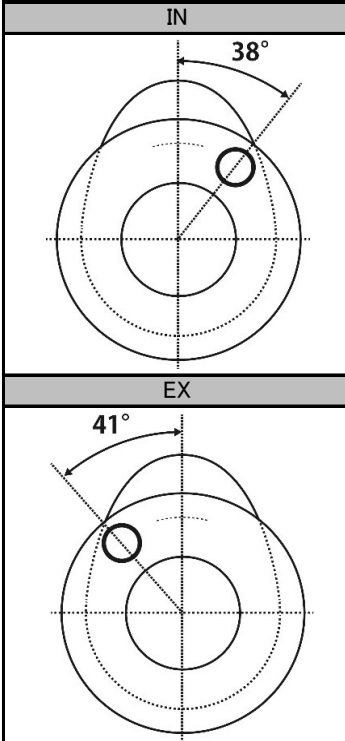

# FRSE Real Speed Engineering Camshaft Spec Card

品名 SPEC-R 適合 G4KF

品番 SET RA301A-HY01B IN RA301C-HY01B EX RA301E-HY01B

スペック	IN	272° / 11.50mm	-
	EX	272° / 11.00mm	-

リフト	IN	@CAM 11.50mm	@VALVE 11.30mm
	EX	@CAM 11.00mm	@VALVE 10.70mm

初期設定 中心角(°)	IN	128.0
	EX	122.0

ベース円	IN	Φ34.4
	EX	Φ36.4

冷間時 バルブクリアランス	IN	0.20
	EX	0.30

ロッカーアームレシオ*	-
-------------	---

\* すべてのリフト値はラッシュアジャスターが動作していない時、およびロッカーアームレシオから計算した理論値です。

カムタイミング		OPENS(°)		CLOSES(°)		Actual Duration @ Opening(°)
有効作用角 バルブリフト	IN	BTDC 8.0	ABDC 84.0			272.0
	EX	BBDC 78.0	ATDC 14.0			272.0

ランプ部を除いた有効作用角の始点と終点の数値

カムタイミング		OPENS(°)		CLOSES(°)		TOTAL DURATION(°)
1mm バルブリフト	IN	BTDC -7.0	ABDC 68.0			241.0
	EX	BBDC 62.0	ATDC -3.0			239.0

ランプ部を含めたバルブの開き始めと閉じ終わりから1mmの点での数値

カムタイミング		OPENS(°)		CLOSES(°)		TOTAL DURATION(°)
0.05" バルブリフト	IN	BTDC -10.0	ABDC 66.0			236.0
	EX	BBDC 59.0	ATDC -6.0			233.0

ランプ部を含めたバルブの開き始めと閉じ終わりから0.05インチの点での数値

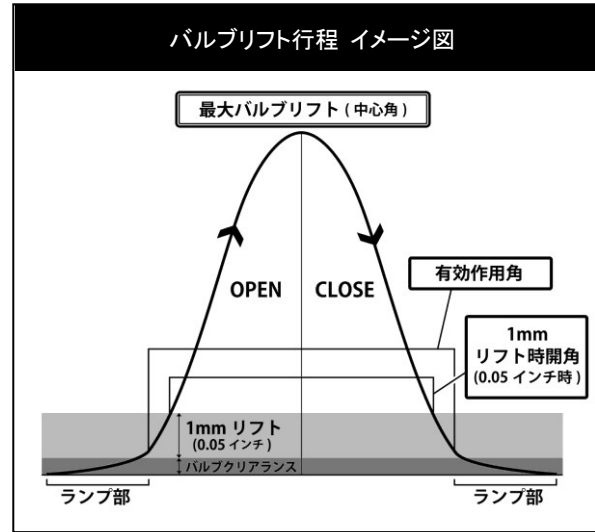

推奨バルブスプリング	
自由長	41.6mm
セット長	35.0mm
リフト長	23.0mm
密着長	21.5mm
セット荷重	27.0kgf ± 7%
リフト荷重	85.0kgf ± 7%
品番	

必要部品	
製品名	品番
1mm リフト時開角(0.05インチ時)	

第1カム山をトップ位置にした際の  
ノックピン位置

