

FRSE Real Speed Engineering Camshaft Spec Card

PART NAME **SPEC-R** ENGINE **VQ35HR**

PART NUMBER SET **RA301A-NS03B** IN **RA301C-NS03B** EX **RA301E-NS03B**

GRIND	IN	274° /11.30mm	-
	EX	274° /11.00mm	-

LIFT	IN	@CAM 11.30mm	@VALVE 11.00mm
	EX	@CAM 11.00mm	@VALVE 10.67mm

LOBE CENTER(°)	IN	122.0
	EX	124.0

BASE CIRCLE	IN	Φ35.4
	EX	Φ35.4

VALVE CLEARANCE WHEN COLD	IN	0.30
	EX	0.33

ROCKER ARM RATIO*	-
-------------------	---

* ALL LIFTS ARE BASED ON ZERO LASH AND THORETICAL ROCKER ARM RATIOS

CAM TIMING		OPENS(°)		CLOSES(°)		Actual Duration @ Opening (°)
Actual Duration Valve Lift	IN	BTDC	14.0	ABDC	80.0	274.0
	EX	BBDC	80.0	ATDC	14.0	274.0

Values shown are, from start to the end of actual duration. (Excluding the ramp values)

CAM TIMING		OPENS(°)		CLOSES(°)		TOTAL DURATION(°)
at 1mm Valve Lift	IN	BTDC	-2.0	ABDC	62.0	240.0
	EX	BBDC	64.0	ATDC	-4.0	240.0

Values are of actual duration from start to end of 1mm value points. (Excluding the ramp values)

CAM TIMING		OPENS(°)		CLOSES(°)		TOTAL DURATION(°)
at 0.05" Valve Lift	IN	BTDC	-4.0	ABDC	60.0	236.0
	EX	BBDC	62.0	ATDC	-6.0	236.0

Values are of actual duration from start to end of 0.05" value points. (Excluding the ramp values)

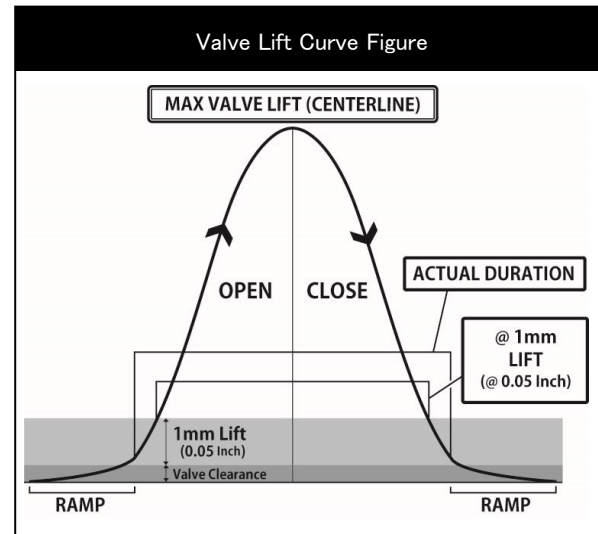

REQUIRED VALVE SPRING SPEC	
NORMAL HEIGHT	49.1mm
SET LENGTH	37.0mm
LIFT LENGTH	26.0mm
COMPRESSED HEIGHT	25.0mm
SET LOAD	24.0kgf ± 6%
LIFT LOAD	56.8kgf ± 6%
PART NUMBER	RA304A-NS04A

REQUIRED PARTS	
PRODUCT NAME	PART NUMBER

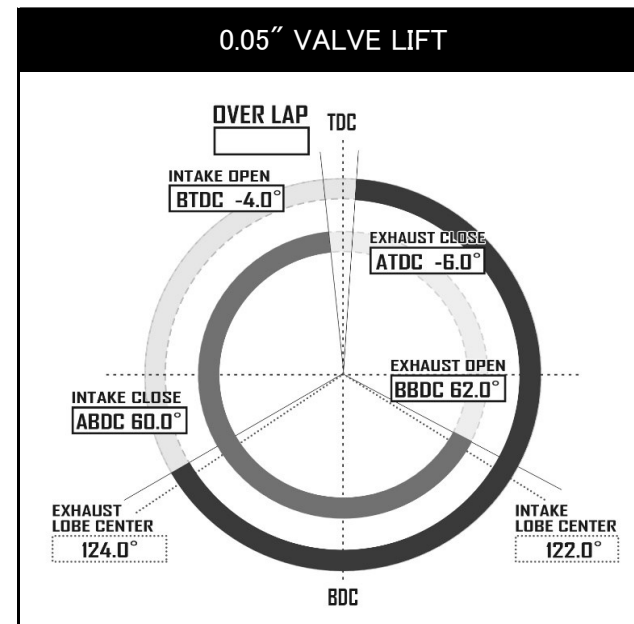
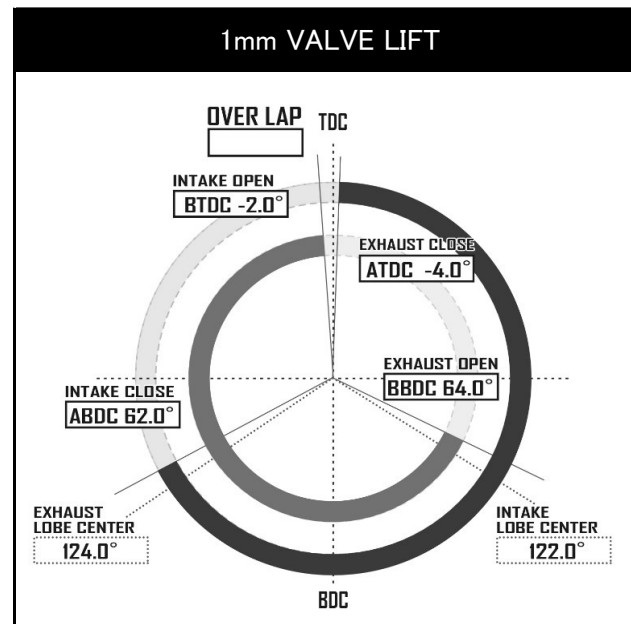
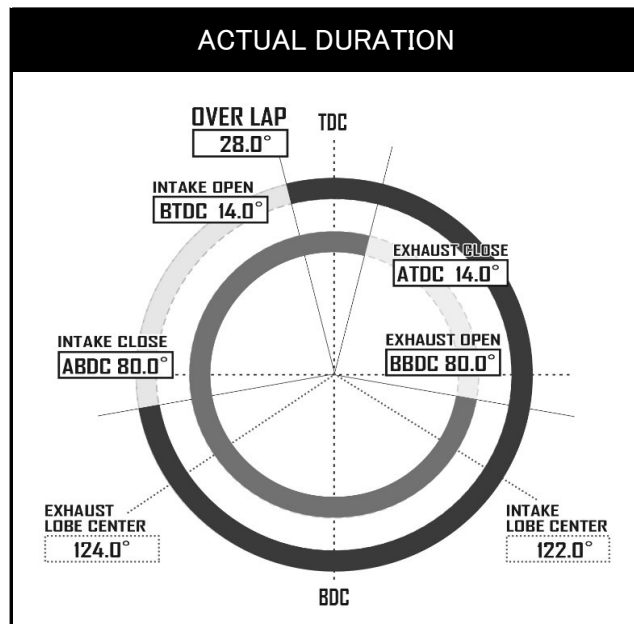

Dowel pin position when first cam lobe is pointing upwards.

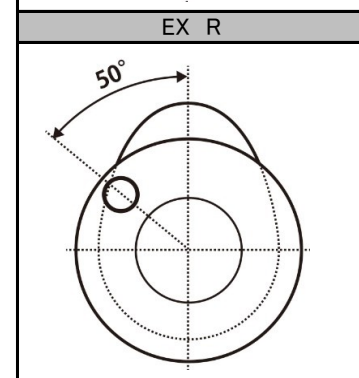
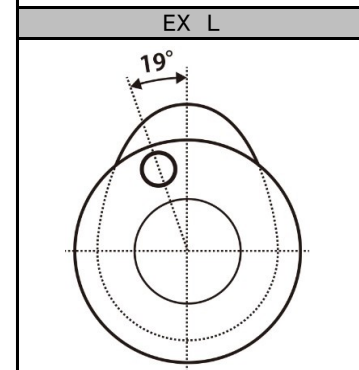
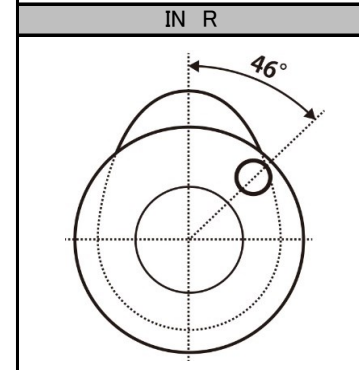
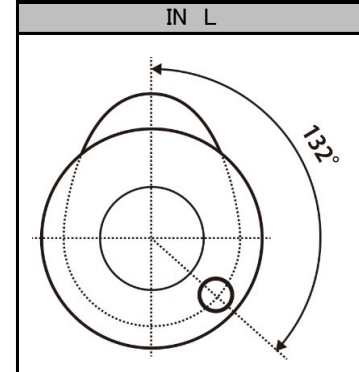

品名 SPEC-R 適合 VQ35HR

品番 SET RA301A-NS03B IN RA301C-NS03B EX RA301E-NS03B

スペック	IN	274° / 11.30mm	-
	EX	274° / 11.00mm	-

リフト	IN	@CAM 11.30mm	@VALVE 11.00mm
	EX	@CAM 11.00mm	@VALVE 10.67mm

初期設定 中心角(°)	IN	122.0
	EX	124.0

ベース円	IN	Φ35.4
	EX	Φ35.4

冷間時 バルブクリアランス	IN	0.30
	EX	0.33

ロッカーアームレシオ*	-
-------------	---

* すべてのリフト値はラッシュアジャスターが動作していない時、およびロッカーアームレシオから計算した理論値です。

カムタイミング		OPENS(°)		CLOSES(°)		Actual Duration @ Opening(°)
有効作用角 バルブリフト	IN	BTDC	14.0	ABDC	80.0	274.0
	EX	BBDC	80.0	ATDC	14.0	274.0

ランプ部を除いた有効作用角の始点と終点の数値

カムタイミング		OPENS(°)		CLOSES(°)		TOTAL DURATION(°)
1mm バルブリフト	IN	BTDC	-2.0	ABDC	62.0	240.0
	EX	BBDC	64.0	ATDC	-4.0	240.0

ランプ部を含めたバルブの開き始めと閉じ終わりから1mmの点での数値

カムタイミング		OPENS(°)		CLOSES(°)		TOTAL DURATION(°)
0.05" バルブリフト	IN	BTDC	-4.0	ABDC	60.0	236.0
	EX	BBDC	62.0	ATDC	-6.0	236.0

ランプ部を含めたバルブの開き始めと閉じ終わりから0.05インチの点での数値

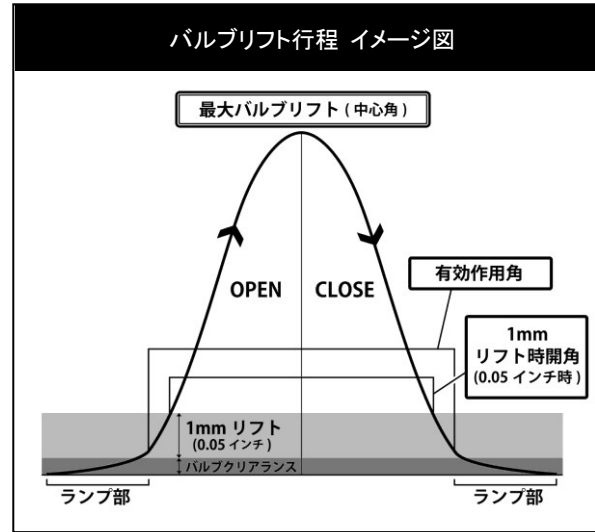

推奨バルブスプリング	
自由長	49.1mm
セット長	37.0mm
リフト長	26.0mm
密着長	25.0mm
セット荷重	24.0kgf ± 6%
リフト荷重	56.8kgf ± 6%
品番	RA304A-NS04A

必要部品	
製品名	品番

