

FRSE Real Speed Engineering Camshaft Spec Card

PART NAME **SPEC-S** ENGINE **EJ207 GRB/GVB JDM EJ257 WRX STI '08 USDM**

PART NUMBER SET **RA301A-SB02C** IN **RA301C-SB02C** EX **RA301E-SB02C**

GRIND	IN	262° /9.80mm	SOLID
	EX	258° /10.80mm	SOLID

LIFT	IN	@CAM 9.80mm	@VALVE 9.60mm
	EX	@CAM 10.80mm	@VALVE 10.40mm

LOBE CENTER(°)	IN	131.0
	EX	130.0

BASE CIRCLE	IN	Φ37.0
	EX	Φ37.0

VALVE CLEARANCE WHEN COLD	IN	0.20
	EX	0.40

ROCKER ARM RATIO*	-
-------------------	---

* ALL LIFTS ARE BASED ON ZERO LASH AND THORETICAL ROCKER ARM RATIOS

CAM TIMING		OPENS(°)		CLOSES(°)		Actual Duration @ Opening(°)
Actual Duration Valve Lift	IN	BTDC	-1.0	ABDC	83.0	262.0
	EX	BBDC	78.0	ATDC	0	258.0

Values shown are, from start to the end of actual duration. (Excluding the ramp values)

CAM TIMING		OPENS(°)		CLOSES(°)		TOTAL DURATION(°)
at 1mm Valve Lift	IN	BTDC	-15.0	ABDC	67.0	232.0
	EX	BBDC	62.0	ATDC	-18.0	224.0

Values are of actual duration from start to end of 1mm value points. (Excluding the ramp values)

CAM TIMING		OPENS(°)		CLOSES(°)		TOTAL DURATION(°)
at 0.05" Valve Lift	IN	BTDC	-17.0	ABDC	65.0	228.0
	EX	BBDC	60.0	ATDC	-20.0	220.0

Values are of actual duration from start to end of 0.05" value points. (Excluding the ramp values)

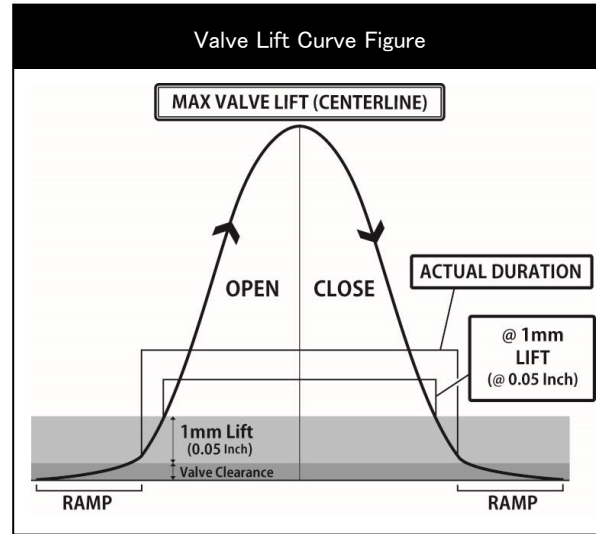

REQUIRED VALVE SPRING SPEC	
NORMAL HEIGHT	OEM or 43.1mm
SET LENGTH	OEM or 36.2mm
LIFT LENGTH	OEM or 25.4mm
COMPRESSED HEIGHT	OEM or 23.1mm
SET LOAD	OEM or 23.8kgf±7%
LIFT LOAD	OEM or 74.8kgf±7%
PART NUMBER	RA304A-SB01A

REQUIRED PARTS	
PRODUCT NAME	PART NUMBER

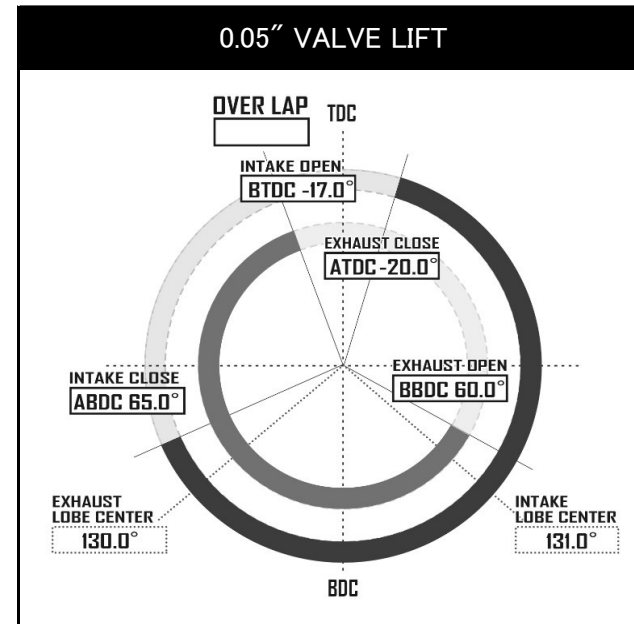
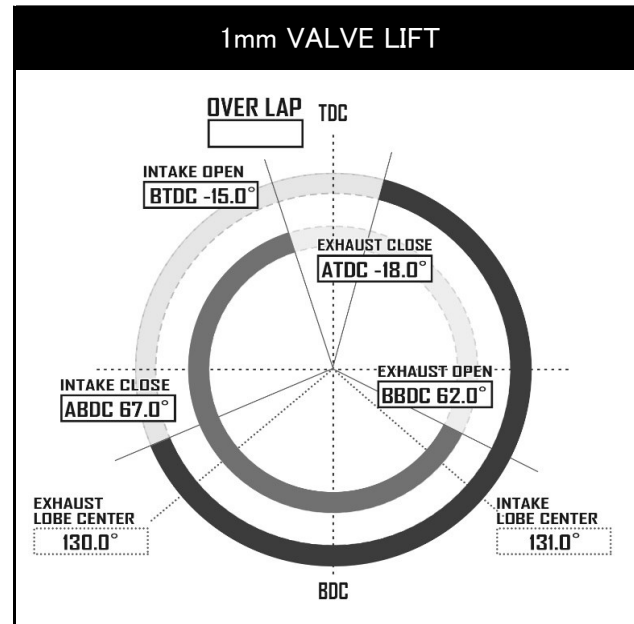
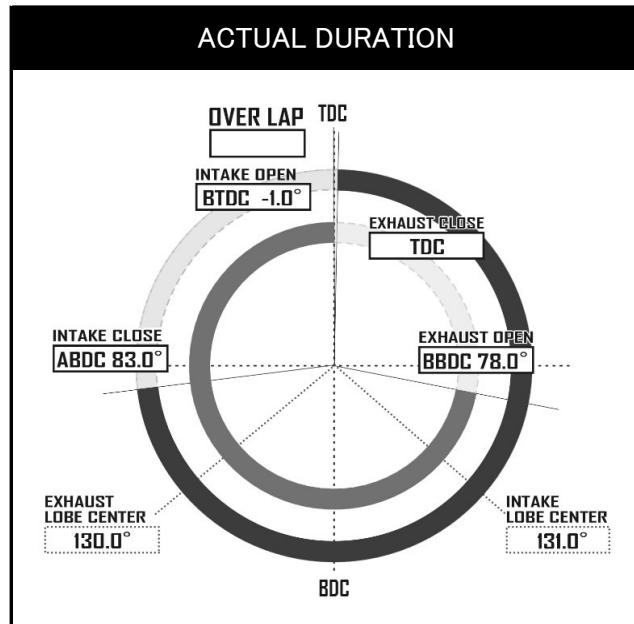

Dowel pin position when first cam lobe is pointing upwards.

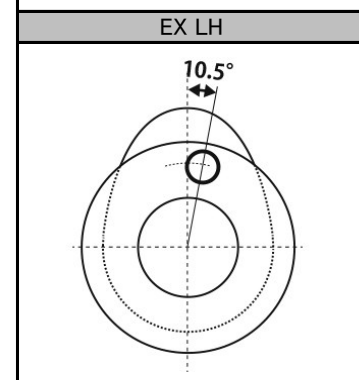
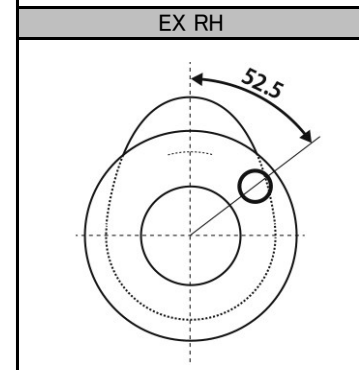
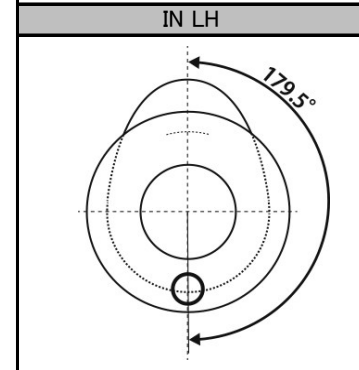
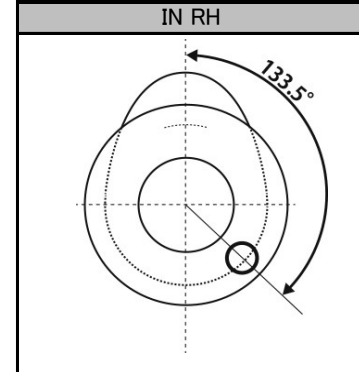

RSE Real Speed Engineering Camshaft Spec Card

品名 SPEC-S エンジン EJ207 GRB/GVB JDM EJ257 WRX STI '08 USDM

品番 SET RA301A-SB02C IN RA301C-SB02C EX RA301E-SB02C

スペック	IN	262° / 9.80mm	SOLID
	EX	258° / 10.80mm	SOLID

リフト	IN	@CAM 9.80mm	@VALVE 9.60mm
	EX	@CAM 10.80mm	@VALVE 10.40mm

初期設定 中心角(°)	IN	131.0
	EX	130.0

ベース円	IN	Φ37.0
	EX	Φ37.0

冷間時 バルブクリアランス	IN	0.20
	EX	0.40

ロッカーアームレシオ*	-
-------------	---

* すべてのリフト値はラッシュアジャスターが動作していない時、およびロッカーアームレシオから計算した理論値です。

カムタイミング		OPENS(°)		CLOSES(°)		Actual Duration @ Opening(°)
有効作用角 バルブリフト	IN	BTDC -1.0	ABDC 83.0	83.0	262.0	
	EX	BBDC 78.0	ATDC 0	0	258.0	

ランプ部を除いた有効作用角の始点と終点の数値

カムタイミング		OPENS(°)		CLOSES(°)		TOTAL DURATION(°)
1mm バルブリフト	IN	BTDC -15.0	ABDC 67.0	67.0	232.0	
	EX	BBDC 62.0	ATDC -18.0	-18.0	224.0	

ランプ部を含めたバルブの開き始めと閉じ終わりから1mmの点での数値

カムタイミング		OPENS(°)		CLOSES(°)		TOTAL DURATION(°)
0.05" バルブリフト	IN	BTDC -17.0	ABDC 65.0	65.0	228.0	
	EX	BBDC 60.0	ATDC -20.0	-20.0	220.0	

ランプ部を含めたバルブの開き始めと閉じ終わりから0.05インチの点での数値

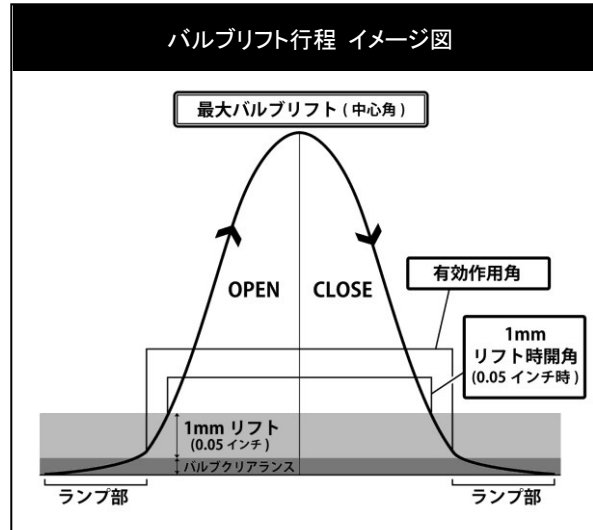

推奨バルブスプリング	
自由長	純正 or 43.1mm
セット長	純正 or 36.2mm
リフト長	純正 or 25.4mm
密着長	純正 or 23.1mm
セット荷重	純正 or 23.8kgf ± 7%
リフト荷重	純正 or 74.8kgf ± 7%
品番	RA304A-SB01A

必要部品	
製品名	品番

第1カム山をトップ位置にした際の
ノックピン位置

