

RSE Camshaft Spec Card

Real Speed Engineering

PART NAME	SPEC-R		ENGINE	2JZ-GTE Early non VVT-i		
PART NUMBER	SET	RA301A-TY03C	IN	RA301C-TY03C	EX	RA301E-TY03C

GRIND	IN	280° /11.00mm	SOLID
	EX	280° /11.00mm	SOLID

LIFT	IN	@CAM 11.00mm	@VALVE 10.80mm
	EX	@CAM 11.00mm	@VALVE 10.70mm

LOBE CENTER(°)	IN	110.0
	EX	115.0

BASE CIRCLE	IN	Φ33.0
	EX	Φ33.0

VALVE CLEARANCE WHEN COLD	IN	0.20mm
	EX	0.30mm

ROCKER ARM RATIO*	-
-------------------	---

* ALL LIFTS ARE BASED ON ZERO LASH AND THORETICAL ROCKER ARM RATIOS

CAM TIMING		OPENS(°)		CLOSES(°)		Actual Duration @ Opening(°)
Actual Duration Valve Lift	IN	BTDC	30.0	ABDC	70.0	280.0
	EX	BBDC	75.0	ATDC	25.0	280.0

Values shown are, from start to the end of actual duration. (Excluding the ramp values)

CAM TIMING		OPENS(°)		CLOSES(°)		TOTAL DURATION(°)
at 1mm Valve Lift	IN	BTDC	14.0	ABDC	54.0	248.0
	EX	BBDC	59.0	ATDC	9.0	248.0

Values are of actual duration from start to end of 1mm value points. (Excluding the ramp values)

CAM TIMING		OPENS(°)		CLOSES(°)		TOTAL DURATION(°)
at 0.05" Valve Lift	IN	BTDC	12.0	ABDC	50.0	242.0
	EX	BBDC	57.0	ATDC	5.0	242.0

Values are of actual duration from start to end of 0.05" value points. (Excluding the ramp values)

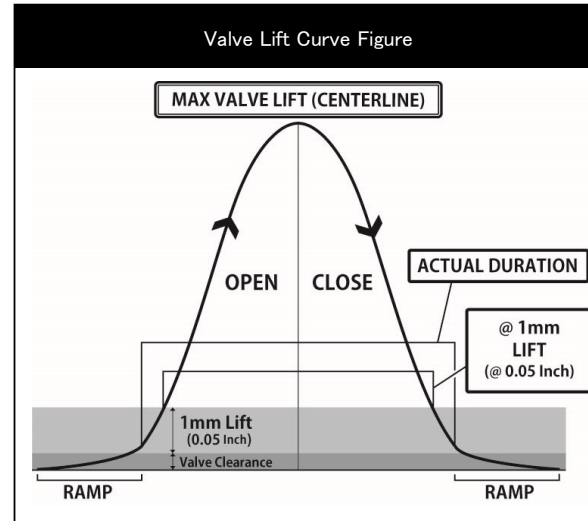

REQUIRED VALVE SPRING SPEC	
NORMAL HEIGHT	45.1mm
SET LENGTH	37.0mm
LIFT LENGTH	25.7mm
COMPRESSED HEIGHT	24.7mm
SET LOAD	24.0kgf±7%
LIFT LOAD	67.0kgf±7%
PART NUMBER	RA312A-TY03A

REQUIRED PARTS	
PRODUCT NAME	PART NUMBER
INNER SHIM KIT	RA312A-TY03A

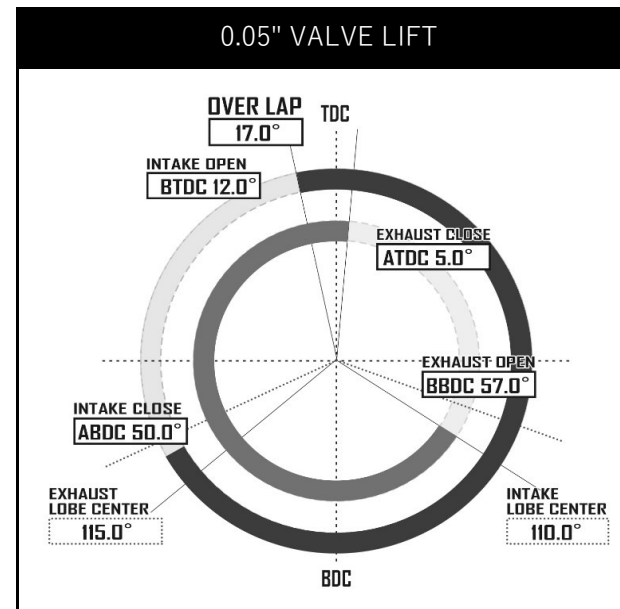
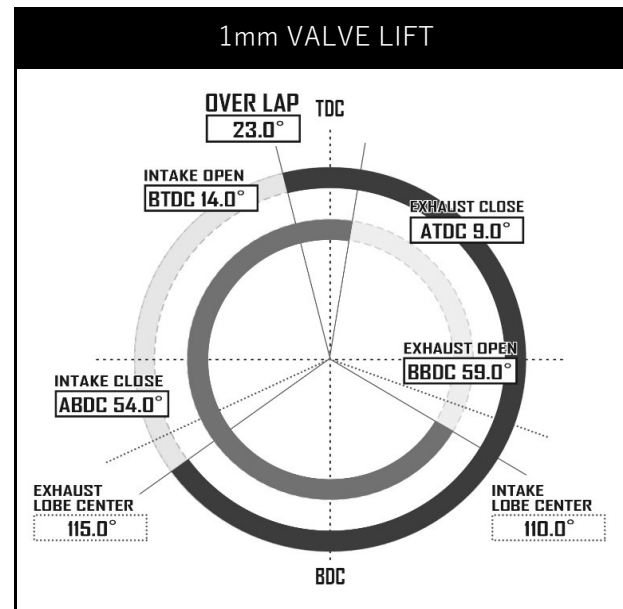
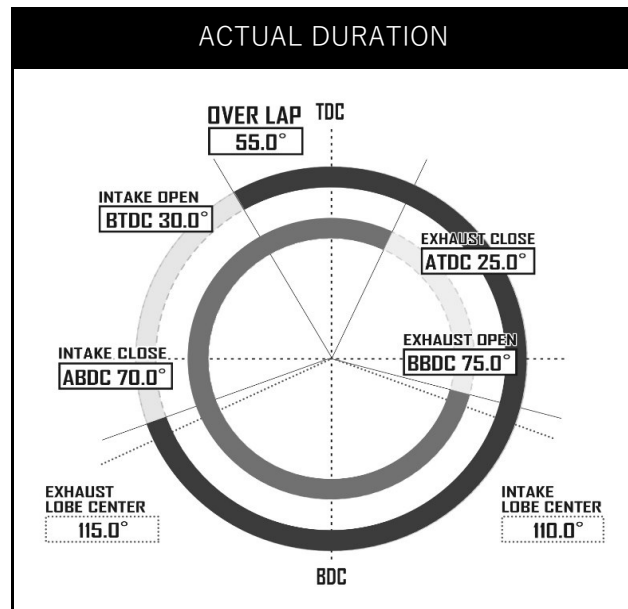

Dowel pin position when first cam lobe is pointing upwards.

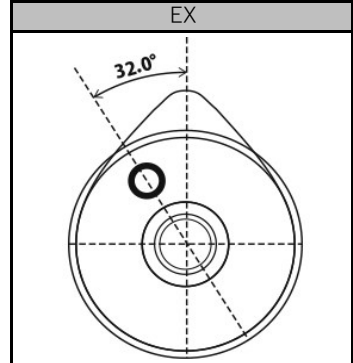
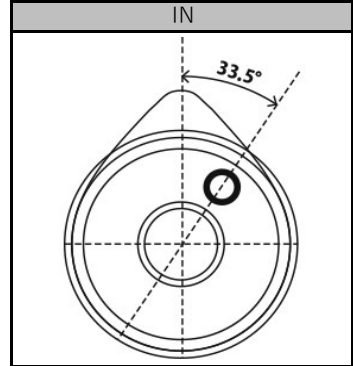

RSE Camshaft Spec Card

Real Speed Engineering

品名 SPEC-R 適合 2JZ-GTE 前期 non VVT-i

品番 SET RA301A-TY03C IN RA301C-TY03C EX RA301E-TY03C

スペック	IN	280° / 11.00mm	SOLID
	EX	280° / 11.00mm	SOLID

リフト	IN	@CAM 11.00mm	@VALVE 10.80mm
	EX	@CAM 11.00mm	@VALVE 10.70mm

初期設定 中心角(°)	IN	110.0
	EX	115.0

ベース円	IN	Φ33.0
	EX	Φ33.0

冷間時 バルブクリアランス	IN	0.20mm
	EX	0.30mm

ロッカーアームレシオ*	-
-------------	---

*すべてのリフト値はラッシュアジャスターが動作していない時、およびロッカーアームレシオから計算した理論値です。

カムタイミング		OPENS(°)		CLOSES(°)		Actual Duration @ Opening(°)
有効作用角 バルブリフト	IN	BTDC	30.0	ABDC	70.0	280.0
	EX	BBDC	75.0	ATDC	25.0	280.0

ランブ部を除いた有効作用角の始点と終点の数値

カムタイミング		OPENS(°)		CLOSES(°)		TOTAL DURATION(°)
1mm バルブリフト	IN	BTDC	14.0	ABDC	54.0	248.0
	EX	BBDC	59.0	ATDC	9.0	248.0

ランブ部を含めたバルブの開き始めと閉じ終わりから1mmの点での数値

カムタイミング		OPENS(°)		CLOSES(°)		TOTAL DURATION(°)
0.05" バルブリフト	IN	BTDC	12.0	ABDC	50.0	242.0
	EX	BBDC	57.0	ATDC	5.0	242.0

ランブ部を含めたバルブの開き始めと閉じ終わりから0.05インチの点での数値

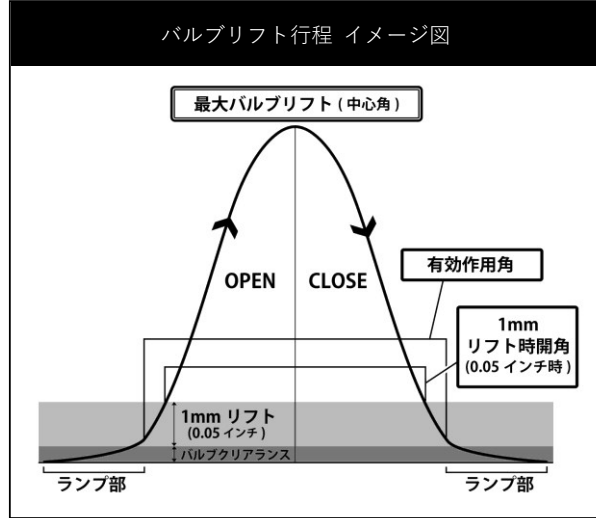

推奨バルブスプリング	
自由長	45.1mm
セット長	37.0mm
リフト長	25.7mm
密着長	24.7mm
セット荷重	24.0kgf±7%
リフト荷重	67.0kgf±7%
品番	RA312A-TY03A

必要部品	
製品名	品番
INNER SHIM KIT	RA312A-TY03A

第1カム山をトップ位置にした際の
ノックピン位置

