

# RSSE Real Speed Engineering Camshaft Spec Card

PART NAME	SPEC-R		ENGINE	2JZ-GTE Late VVT-i		
PART NUMBER	SET	RA301A-TY03F	IN	RA301C-TY03F	EX	RA301E-TY03F

GRIND	IN	270° /11.00mm	SOLID	LIFT	IN	@CAM 11.00mm	@VALVE 10.80mm	LOBE CENTER(°)	IN	123.0	BASE	IN	Φ33.0
	EX	270° /11.00mm	SOLID		EX	@CAM 11.00mm	@VALVE 10.70mm		EX	116.0		EX	Φ33.0

VALVE CLEARANCE WHEN COLD	IN	0.20mm	ROCKER ARM RATIO*	* ALL LIFTS ARE BASED ON ZERO LASH AND THORETICAL ROCKER ARM RATIOS	
	EX	0.30mm		-	

CAM TIMING		OPENS(°)		CLOSES(°)		Actual Duration @ Opening(°)
Actual Duration	IN	BTDC	11.0	ABDC	79.0	270.0
Valve Lift	EX	BBDC	70.0	ATDC	20.0	270.0

Values shown are, from start to the end of actual duration. (Excluding the ramp values)

CAM TIMING		OPENS(°)		CLOSES(°)		TOTAL DURATION(°)
at 1mm Valve Lift	IN	BTDC	-5.0	ABDC	63.0	238.0
	EX	BBDC	54.0	ATDC	4.0	238.0

Values are of actual duration from start to end of 1mm value points. (Excluding the ramp values)

CAM TIMING		OPENS(°)		CLOSES(°)		TOTAL DURATION(°)
at 0.05" Valve Lift	IN	BTDC	-7.0	ABDC	59.0	232.0
	EX	BBDC	52.0	TDC		232.0

Values are of actual duration from start to end of 0.05" value points. (Excluding the ramp values)

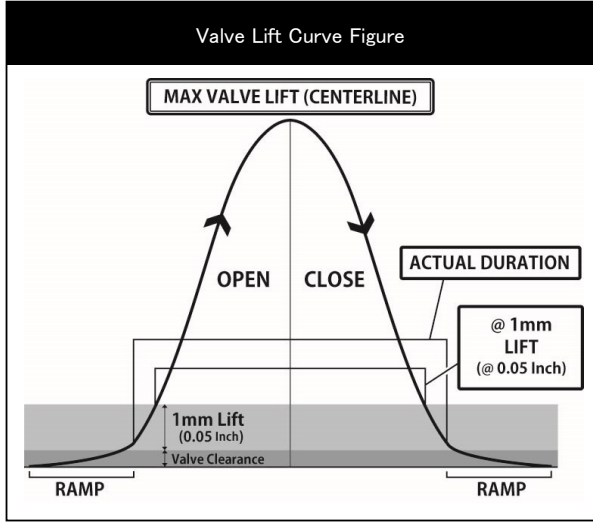

REQUIRED VALVE SPRING SPEC	
NORMAL HEIGHT	45.1mm
SET LENGTH	37.0mm
LIFT LENGTH	25.7mm
COMPRESSED HEIGHT	24.7mm
SET LOAD	24.0kgf ± 7%
LIFT LOAD	67.0kgf ± 7%
PART NUMBER	RA312A-TY03A

REQUIRED PARTS	
PRODUCT NAME	PART NUMBER
INNER SHIM KIT	RA312A-TY03A

Dowel pin position when first cam lobe is pointing upwards.

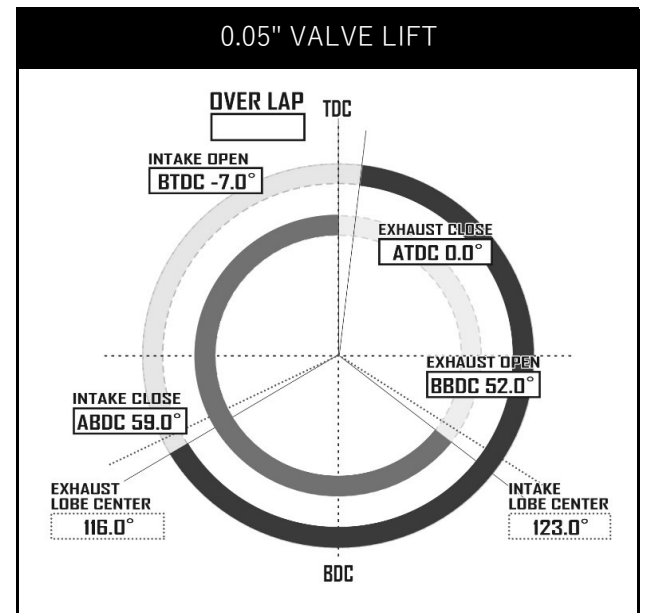
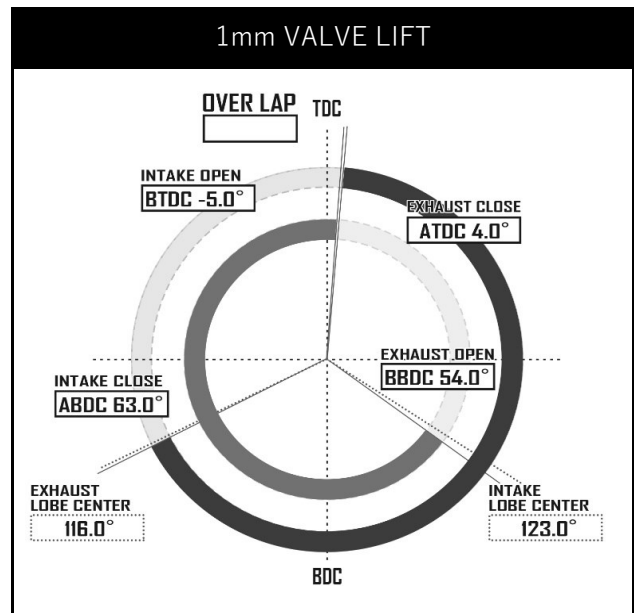
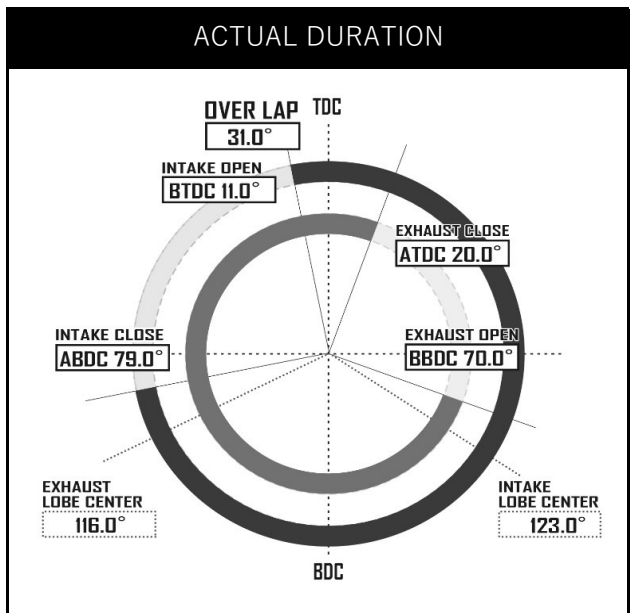
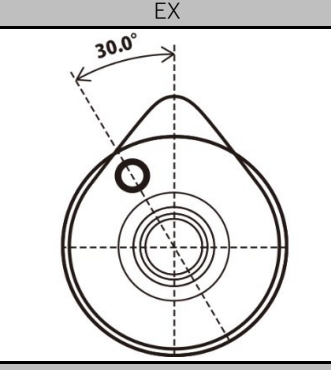
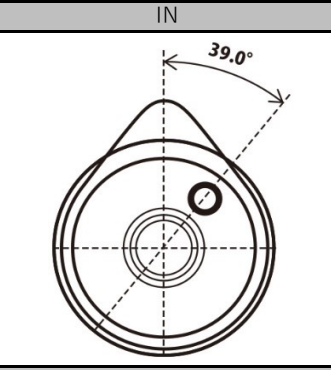

# RSE Camshaft Spec Card

Real Speed Engineering

品名	SPEC-R		適合	2JZ-GTE 後期 VVT-i	
品番	SET	RA301A-TY03F	IN	RA301C-TY03F	EX RA301E-TY03F

スペック	IN	270° / 11.00mm	SOLID
	EX	270° / 11.00mm	SOLID

リフト	IN	@CAM 11.00mm	@VALVE 10.80mm
	EX	@CAM 11.00mm	@VALVE 10.70mm

初期設定 中心角(°)	IN	123.0
	EX	116.0

ベース円	IN	Φ33.0
	EX	Φ33.0

冷間時 バルブクリアランス	IN	0.20mm
	EX	0.30mm

ロッカーアームレシオ*	-
-------------	---

\* すべてのリフト値はラッシュアジャスターが動作していない時、およびロッカーアームレシオから計算した理論値です。

カムタイミング		OPENS(°)		CLOSES(°)		有効作用角時 開角(°)
有効作用角 バルブリフト	IN	BTDC	11.0	ABDC	79.0	270.0
	EX	BBDC	70.0	ATDC	20.0	270.0

ランプ部を除いた有効作用角の始点と終点の数値

カムタイミング		OPENS(°)		CLOSES(°)		1mmリフト時 開角(°)
1mm バルブリフト	IN	BTDC	-5.0	ABDC	63.0	238.0
	EX	BBDC	54.0	ATDC	4.0	238.0

ランプ部を含めたバルブの開き始めと閉じ終わりから1mmの点での数値

カムタイミング		OPENS(°)		CLOSES(°)		0.05"リフト時 開角(°)
0.05" バルブリフト	IN	BTDC	-7.0	ABDC	59.0	232.0
	EX	BBDC	52.0	TDC		232.0

ランプ部を含めたバルブの開き始めと閉じ終わりから0.05インチの点での数値

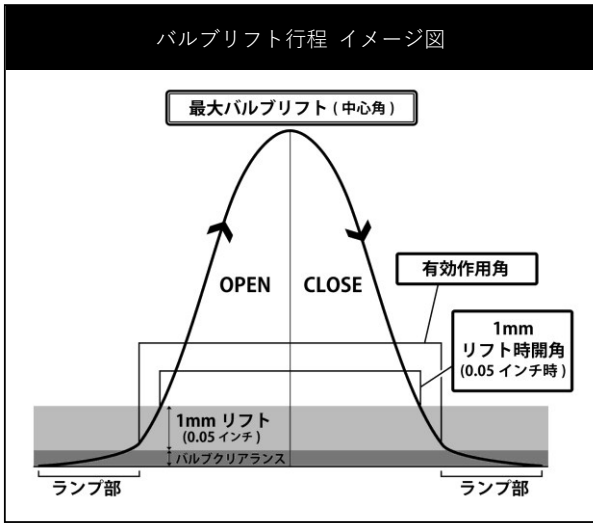

推奨バルブスプリング	
自由長	45.1mm
セット長	37.0mm
リフト長	25.7mm
密着長	24.7mm
セット荷重	24.0kgf ± 7%
リフト荷重	67.0kgf ± 7%
品番	RA312A-TY03A

必要部品	
製品名	品番
インナーシムキット	RA312A-TY03A

