

# RSE Camshaft Spec Card

Real Speed Engineering

PART NAME SPEC-S ENGINE 1JZ-GTE VVT-i

PART NUMBER SET RA301A-TY04A IN RA301C-TY04A EX RA301E-TY04A

GRIND	IN	260° /8.90mm	SOLID
	EX	260° /9.10mm	SOLID

LIFT	IN	@CAM 8.90mm	@VALVE 8.70mm
	EX	@CAM 9.10mm	@VALVE 8.80mm

LOBE CENTER(°)	IN	119.0
	EX	112.0

BASE	IN	Φ36.0
CIRCLE	EX	Φ36.0

VALVE CLEARANCE WHEN COLD	IN	0.20mm
	EX	0.30mm

ROCKER ARM RATIO*	-
-------------------	---

\* ALL LIFTS ARE BASED ON ZERO LASH AND THORETICAL ROCKER ARM RATIOS

CAM TIMING		OPENS(°)		CLOSES(°)		Actual Duration @ Opening(°)
Actual Duration Valve Lift	IN	BTDC	11.0	ABDC	69.0	260.0
	EX	BBDC	62.0	ATDC	18.0	260.0

Values shown are, from start to the end of actual duration. (Excluding the ramp values)

CAM TIMING		OPENS(°)		CLOSES(°)		TOTAL DURATION(°)
at 1mm Valve Lift	IN	BTDC	-5.0	ABDC	53.0	228.0
	EX	BBDC	46.0	ATDC	0.0	226.0

Values are of actual duration from start to end of 1mm value points. (Excluding the ramp values)

CAM TIMING		OPENS(°)		CLOSES(°)		TOTAL DURATION(°)
at 0.05" Valve Lift	IN	BTDC	-7.0	ABDC	49.0	222.0
	EX	BBDC	44.0	ATDC	-2.0	222.0

Values are of actual duration from start to end of 0.05" value points. (Excluding the ramp values)

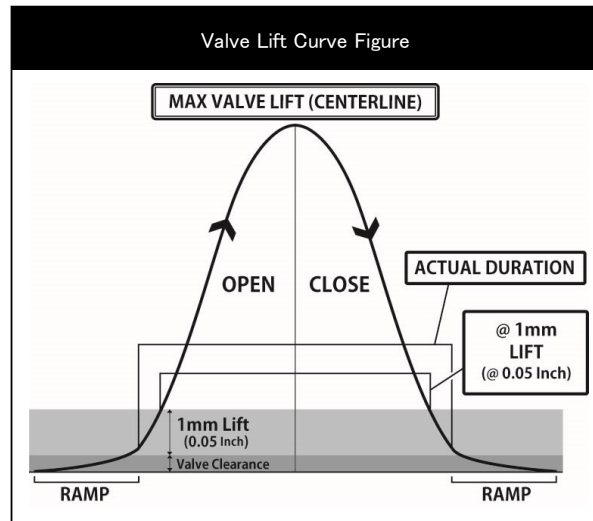

REQUIRED VALVE SPRING SPEC	
NORMAL HEIGHT	
SET LENGTH	
LIFT LENGTH	
COMPRESSED HEIGHT	
SET LOAD	
LIFT LOAD	
PART NUMBER	

REQUIRED PARTS	
PRODUCT NAME	PART NUMBER

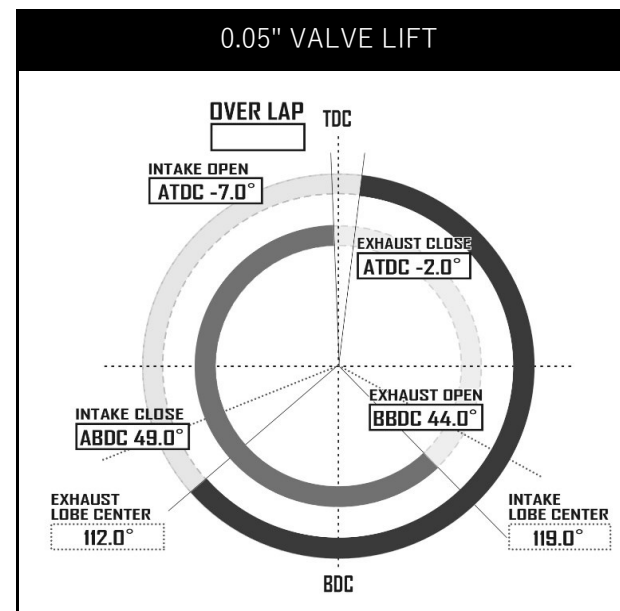
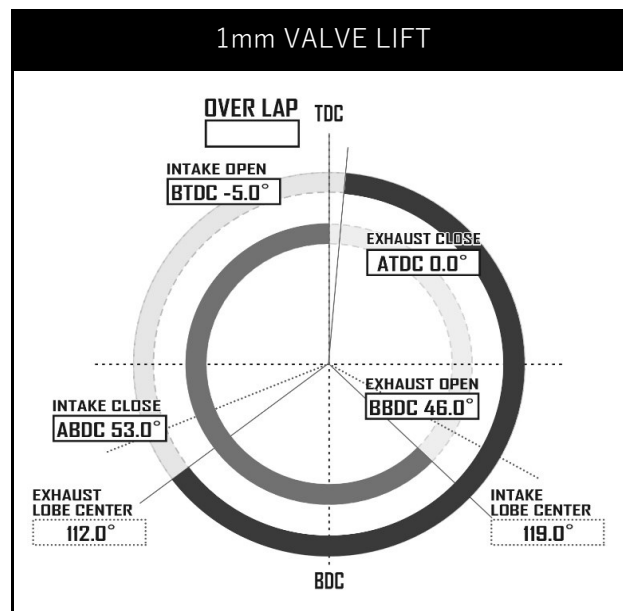
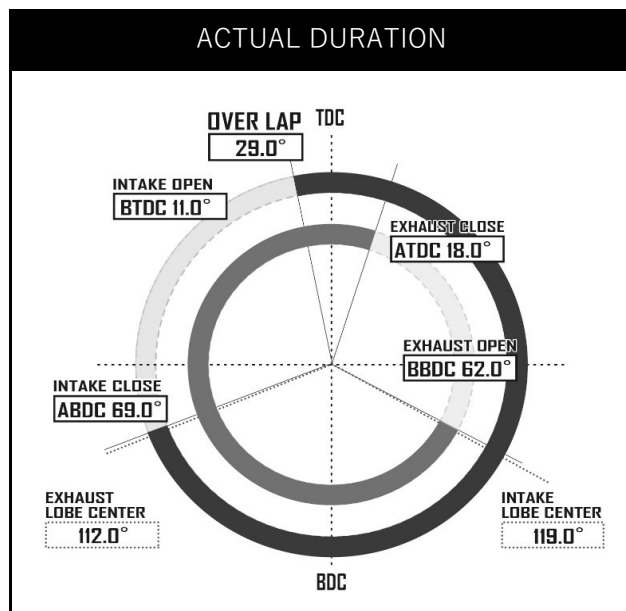

Dowel pin position when first cam lobe is pointing upwards.

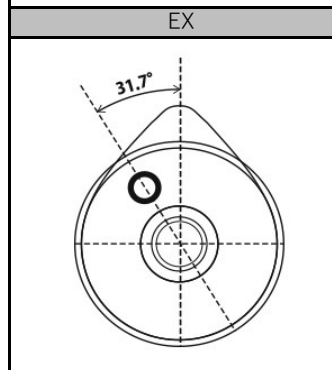
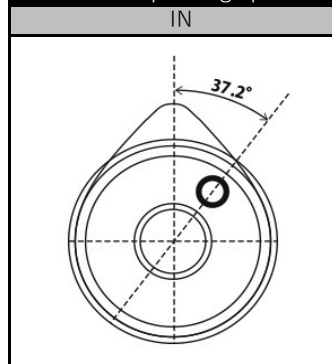

# RSE Camshaft Spec Card

品名 SPEC-S 適合 1JZ-GTE VVT-i

品番 SET RA301A-TY04A IN RA301C-TY04A EX RA301E-TY04A

スペック	IN	260° /8.90mm	SOLID
	EX	260° /9.10mm	SOLID

リフト	IN	@CAM 8.90mm	@VALVE 8.70mm
	EX	@CAM 9.10mm	@VALVE 8.80mm

初期設定 中心角(°)	IN	119.0
	EX	112.0

ベース円	IN	Φ36.0
	EX	Φ36.0

冷間時 バルブクリアランス	IN	0.20mm
	EX	0.30mm

ロッカーアームレシオ*	-
-------------	---

\*すべてのリフト値はラッシュアジャスターが動作していない時、およびロッカーアームレシオから計算した理論値です。

カムタイミング		OPENS(°)		CLOSES(°)		Actual Duration @ Opening(°)
有効作用角 バルブリフト	IN	BTDC	11.0	ABDC	69.0	260.0
	EX	BBDC	62.0	ATDC	18.0	260.0

ランブ部を除いた有効作用角の始点と終点の数値

カムタイミング		OPENS(°)		CLOSES(°)		TOTAL DURATION(°)
1mm バルブリフト	IN	BTDC	-5.0	ABDC	53.0	228.0
	EX	BBDC	46.0	ATDC	0.0	226.0

ランブ部を含めたバルブの開き始めと閉じ終わりから1mmの点での数値

カムタイミング		OPENS(°)		CLOSES(°)		TOTAL DURATION(°)
0.05" バルブリフト	IN	BTDC	-7.0	ABDC	49.0	222.0
	EX	BBDC	44.0	ATDC	-2.0	222.0

ランブ部を含めたバルブの開き始めと閉じ終わりから0.05インチの点での数値

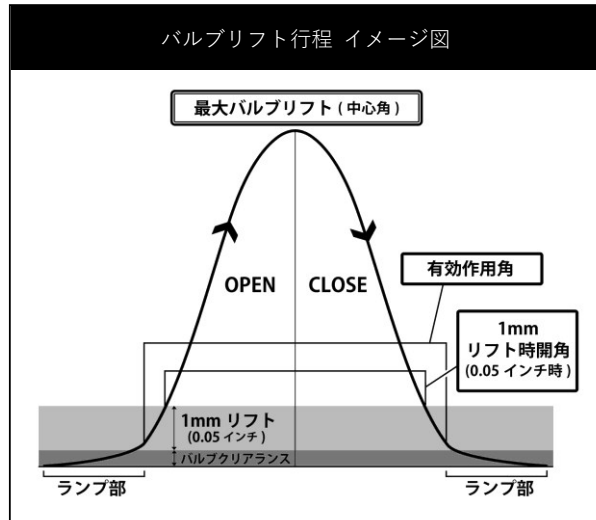

推奨バルブスプリング	
自由長	
セット長	
リフト長	
密着長	
セット荷重	
リフト荷重	
品番	

必要部品	
製品名	品番

第1カム山をトップ位置にした際の  
ノックピン位置

