

RSE Real Speed Engineering Camshaft Spec Card

PART NAME **SPEC-S** ENGINE **4G63 EVO 9**

PART NUMBER SET **RA301B-MT01B** IN **RA301D-MT01B** EX **RA301F-MT01B**

GRIND	IN	272° /10.70mm	LASH
	EX	272° /10.20mm	LASH

LIFT	IN	@CAM 6.17mm	@VALVE 10.70mm
	EX	@CAM 5.88mm	@VALVE 10.20mm

LOBE CENTER(°)	IN	130.0
	EX	110.0

BASE CIRCLE	IN	Φ30.0
	EX	Φ30.0

VALVE CLEARANCE WHEN COLD	IN	-
	EX	-

ROCKER ARM RATIO*	1.73
-------------------	------

* ALL LIFTS ARE BASED ON ZERO LASH AND THORETICAL ROCKER ARM RATIOS

CAM TIMING		OPENS(°)	CLOSES(°)		Actual Duration @ Opening(°)
Actual Duration Valve Lift	IN	BTDC 6.0	ABDC 86.0		272.0
	EX	BBDC 66.0	ATDC 26.0		272.0

Values shown are, from start to the end of actual duration. (Excluding the ramp values)

CAM TIMING		OPENS(°)	CLOSES(°)		TOTAL DURATION(°)
at 1mm Valve Lift	IN	BTDC -16.0	ABDC 64.0		228.0
	EX	BBDC 44.0	ATDC 4.0		228.0

Values are of actual duration from start to end of 1mm value points. (Excluding the ramp values)

CAM TIMING		OPENS(°)	CLOSES(°)		TOTAL DURATION(°)
at 0.05" Valve Lift	IN	BTDC -19.0	ABDC 62.0		223.0
	EX	BBDC 41.0	ATDC 2.0		223.0

Values are of actual duration from start to end of 0.05" value points. (Excluding the ramp values)

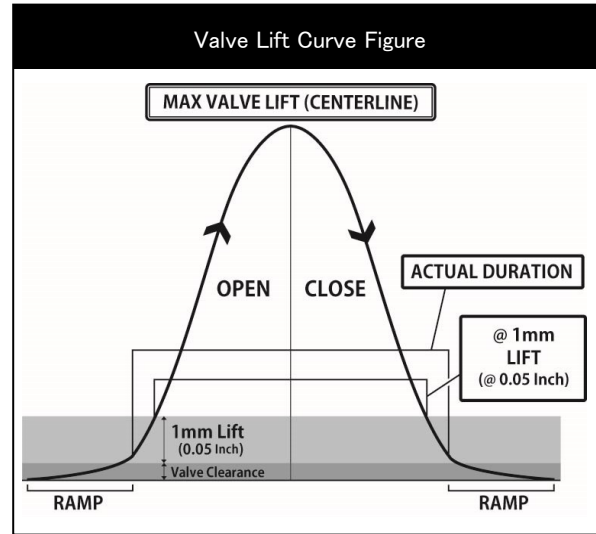

REQUIRED VALVE SPRING SPEC	
NORMAL HEIGHT	OEM or 50.1mm
SET LENGTH	OEM or 39.6mm
LIFT LENGTH	OEM or 27.2mm
COMPRESSED HEIGHT	OEM or 26.2mm
SET LOAD	OEM or 33.7kgf±7%
LIFT LOAD	OEM or 85.5kgf±7%
PART NUMBER	RA304A-MT01A

REQUIRED PARTS	
PRODUCT NAME	PART NUMBER

Dowel pin position when first cam lobe is pointing upwards.

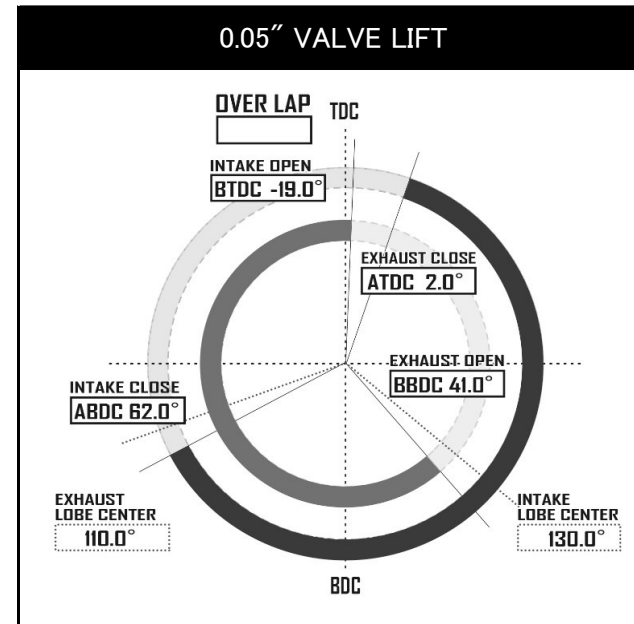
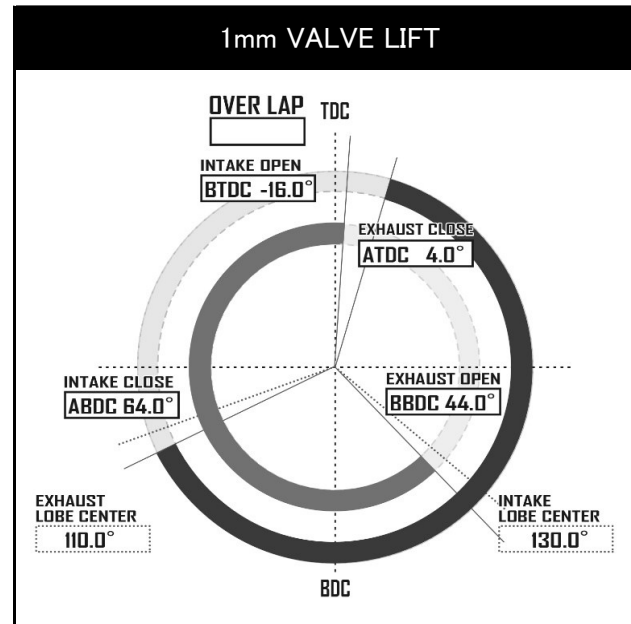
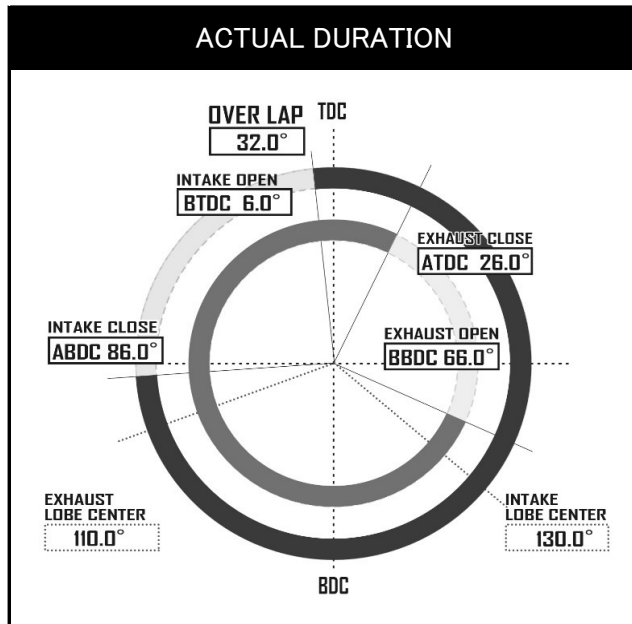
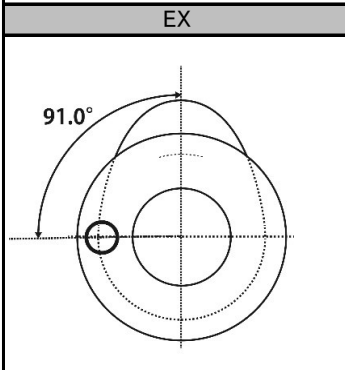
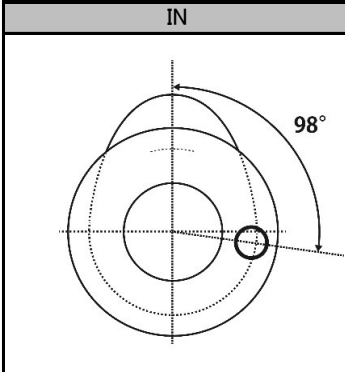

RSE Real Speed Engineering Camshaft Spec Card

品名 SPEC-S 適合 4G63 EVO 9

品番 SET RA301B-MT01B IN RA301D-MT01B EX RA301F-MT01B

スペック	IN	272° / 10.70mm	LASH
	EX	272° / 10.20mm	LASH

リフト	IN	@CAM 6.17mm	@VALVE 10.70mm
	EX	@CAM 5.88mm	@VALVE 10.20mm

初期設定 中心角(°)	IN	130.0
	EX	110.0

ベース円	IN	Φ30.0
	EX	Φ30.0

冷間時	IN	-
バルブクリアランス	EX	-

ロッカーアームレシオ*	1.73
-------------	------

* すべてのリフト値はラッシュアジャスターが動作していない時、およびロッカーアームレシオから計算した理論値です。

カムタイミング		OPENS(°)		CLOSES(°)		Actual Duration @ Opening(°)
有効作用角 バルブリフト	IN	BTDC	6.0	ABDC	86.0	272.0
	EX	BBDC	66.0	ATDC	26.0	272.0

ランプ部を除いた有効作用角の始点と終点の数値

カムタイミング		OPENS(°)		CLOSES(°)		TOTAL DURATION(°)
1mm バルブリフト	IN	BTDC	-16.0	ABDC	64.0	228.0
	EX	BBDC	44.0	ATDC	4.0	228.0

ランプ部を含めたバルブの開き始めと閉じ終わりから1mmの点での数値

カムタイミング		OPENS(°)		CLOSES(°)		TOTAL DURATION(°)
0.05" バルブリフト	IN	BTDC	-19.0	ABDC	62.0	223.0
	EX	BBDC	41.0	ATDC	2.0	223.0

ランプ部を含めたバルブの開き始めと閉じ終わりから0.05インチの点での数値

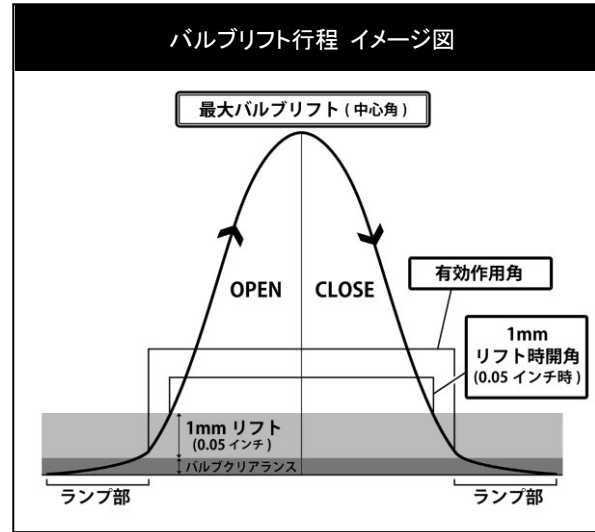

推奨バルブスプリング		
自由長	純正 or	50.1mm
セット長	純正 or	39.6mm
リフト長	純正 or	27.2mm
密着長	純正 or	26.2mm
セット荷重	純正 or	33.7kgf ± 7%
リフト荷重	純正 or	85.5kgf ± 7%
品番		RA304A-MT01A

必要部品	
製品名	品番

第1カム山をトップ位置にした際の
ノックピン位置

