

RSE Real Speed Engineering Camshaft Spec Card

PART NAME **SPEC-S** ENGINE **4AG 4VALVE**

PART NUMBER SET **-** IN **RA301C-TY01A** EX **RA301E-TY01A**

GRIND	IN	258° /8.15mm	SOLID
	EX	258° /8.15mm	SOLID

LIFT	IN	@CAM 8.15mm	@VALVE 7.95mm
	EX	@CAM 8.15mm	@VALVE 7.90mm

LOBE CENTER(°)	IN	105.0
	EX	110.0

BASE CIRCLE	IN	Φ28.0
	EX	Φ28.0

VALVE CLEARANCE WHEN COLD	IN	0.20
	EX	0.25

ROCKER ARM RATIO*	-
-------------------	---

* ALL LIFTS ARE BASED ON ZERO LASH AND THORETICAL ROCKER ARM RATIOS

CAM TIMING		OPENS(°)		CLOSES(°)		Actual Duration @ Opening (°)
Actual Duration Valve Lift	IN	BTDC	23.0	ABDC	55.0	258.0
	EX	BBDC	58.0	ATDC	20.0	258.0

Values shown are, from start to the end of actual duration. (Excluding the ramp values)

CAM TIMING		OPENS(°)		CLOSES(°)		TOTAL DURATION(°)
at 1mm Valve Lift	IN	BTDC	7.0	ABDC	39.0	226.0
	EX	BBDC	42.0	ATDC	2.0	224.0

Values are of actual duration from start to end of 1mm value points. (Excluding the ramp values)

CAM TIMING		OPENS(°)		CLOSES(°)		TOTAL DURATION(°)
at 0.05" Valve Lift	IN	BTDC	5.0	ABDC	35.0	220.0
	EX	BBDC	38.0	ATDC	0.0	218.0

Values are of actual duration from start to end of 0.05" value points. (Excluding the ramp values)

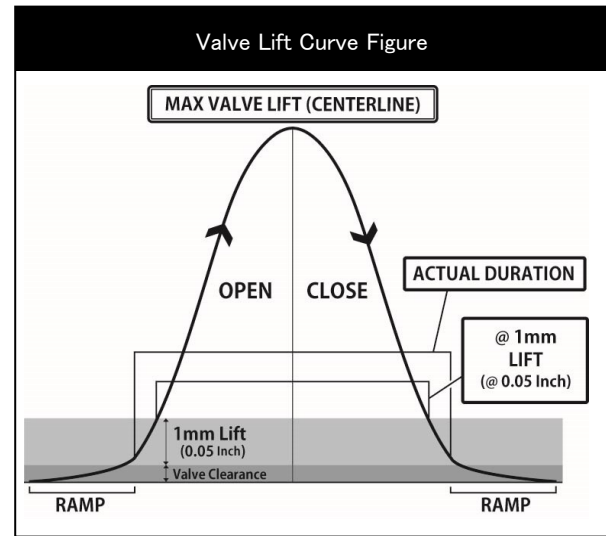

REQUIRED VALVE SPRING SPEC	
NORMAL HEIGHT	
SET LENGTH	
LIFT LENGTH	
COMPRESSED HEIGHT	
SET LOAD	
LIFT LOAD	
PART NUMBER	

REQUIRED PARTS	
PRODUCT NAME	PART NUMBER
VALVE SPRING	OEM or UPRATED
ADJUSTABLE CAM GEAR	OEM or UPRATED

Dowel pin position when first cam lobe is pointing upwards.

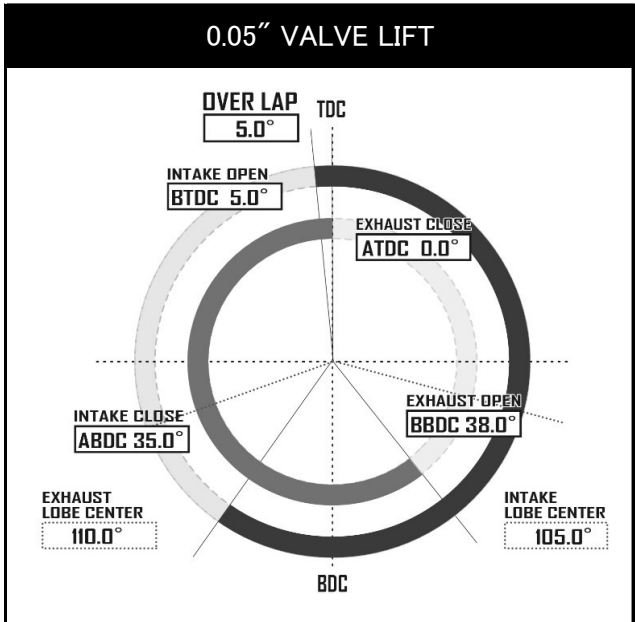
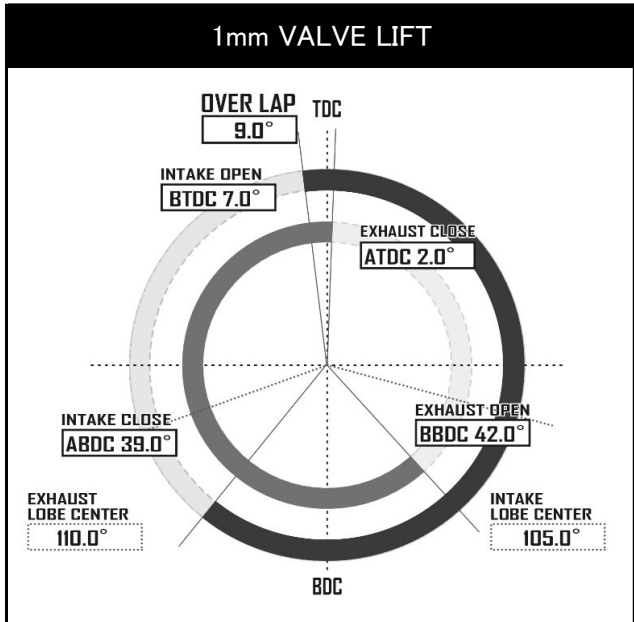
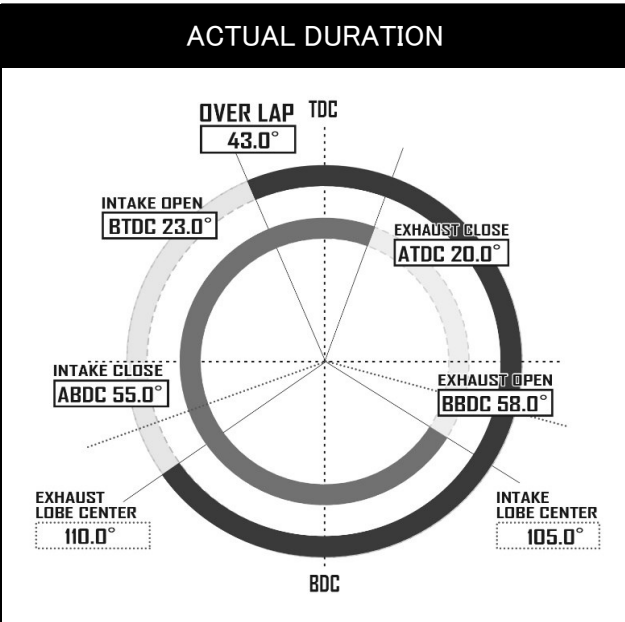
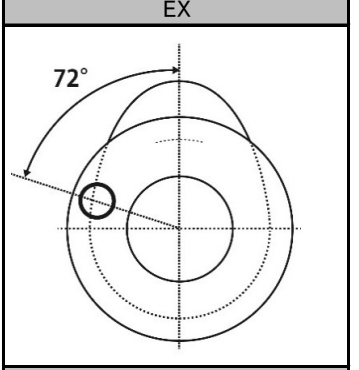
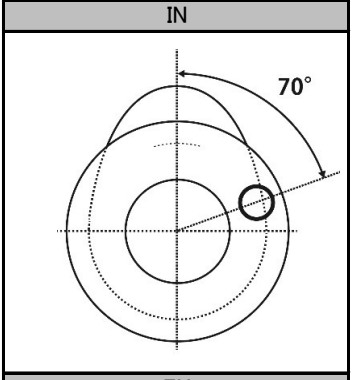

RSSE Real Speed Engineering Camshaft Spec Card

品名 SPEC-S 適合 4AG 4VALVE

品番 SET - IN RA301C-TY01A EX RA301E-TY01A

スペック	IN	258° / 8.15mm	SOLID
	EX	258° / 8.15mm	SOLID

リフト	IN	@CAM 8.15mm	@VALVE 7.95mm
	EX	@CAM 8.15mm	@VALVE 7.90mm

初期設定 中心角(°)	IN	105.0
	EX	110.0

ベース円	IN	Φ28.0
	EX	Φ28.0

冷間時 バルブクリアランス	IN	0.20
	EX	0.25

ロッカーアームレシオ*	-
-------------	---

*すべてのリフト値はラッシュアジャスターが動作していない時、およびロッカーアームレシオから計算した理論値です。

カムタイミング		OPENS(°)		CLOSES(°)		Actual Duration @ Opening(°)
有効作用角 バルブリフト	IN	BTDC	23.0	ABDC	55.0	258.0
	EX	BBDC	58.0	ATDC	20.0	258.0

ランプ部を除いた有効作用角の始点と終点の数値

カムタイミング		OPENS(°)		CLOSES(°)		TOTAL DURATION(°)
1mm バルブリフト	IN	BTDC	7.0	ABDC	39.0	226.0
	EX	BBDC	42.0	ATDC	2.0	224.0

ランプ部を含めたバルブの開き始めと閉じ終わりから1mmの点での数値

カムタイミング		OPENS(°)		CLOSES(°)		TOTAL DURATION(°)
0.05" バルブリフト	IN	BTDC	5.0	ABDC	35.0	220.0
	EX	BBDC	38.0	ATDC	0.0	218.0

ランプ部を含めたバルブの開き始めと閉じ終わりから0.05インチの点での数値

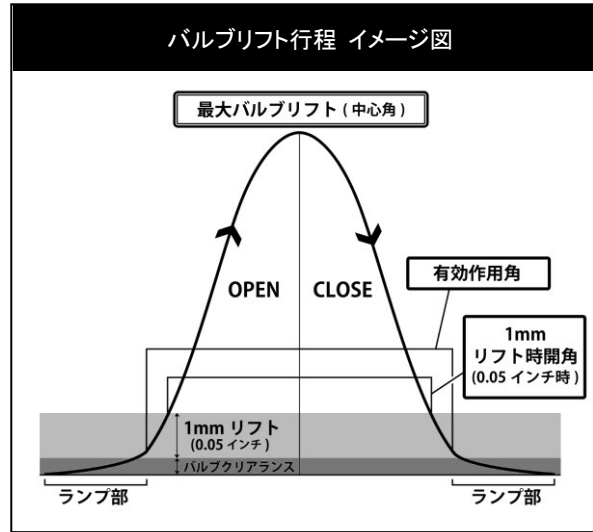

推奨バルブスプリング	
自由長	
セット長	
リフト長	
密着長	
セット荷重	
リフト荷重	
品番	

必要部品	
製品名	品番
バルブスプリング	純正 or 強化版
アジャスタブルカムギア	純正 or 強化版

第1カム山をトップ位置にした際の
ノックピン位置

